

Upper Hopper
reinforcement 2x3 or 2x4s
4 at about 20" long for each hopper
It makes it easier and more
secure to screw the
3/4" plywood together.

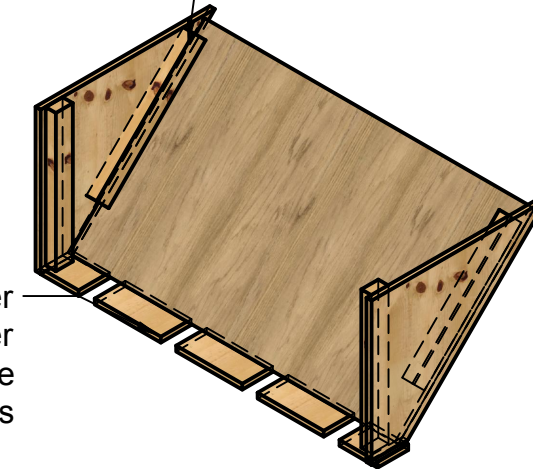

Cut spacers to fit under
the upper hopper
and between the
bagger troughs

about 9 11/16" long by 4 1/2" wide between baggers
beneficial to do a mitre (angled) cut
but not essential

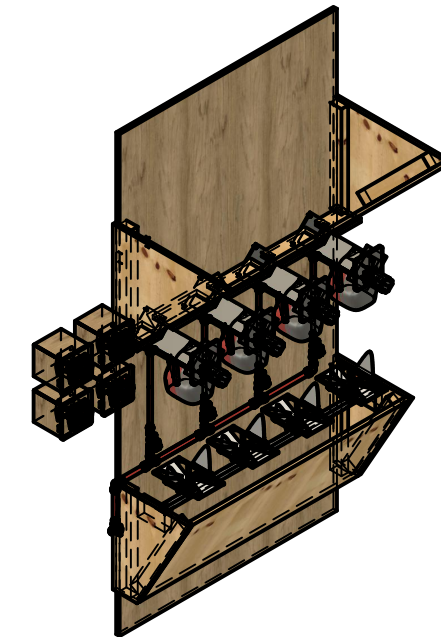

Fully Assembled 4 bagger system

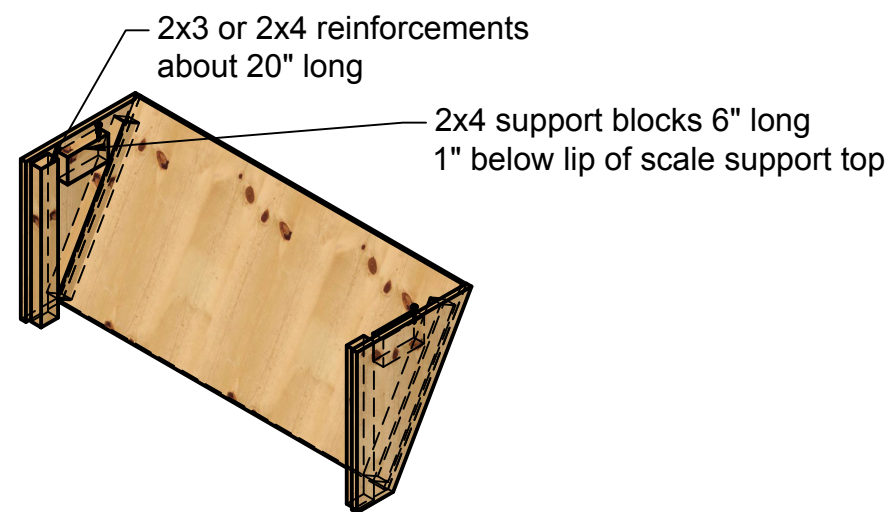

lower scale support and spill catch

		PROJECT		
		Fenrir Bagger Hopper Plans		
		TITLE		
		Hopper Plans 3/4" Plywood		
APPROVED	SIZE	CODE	DWG NO	REV
CHECKED	B			
DRAWN Fenrir	2022-05-20	SCALE 1:30	WEIGHT	SHEET 1/3

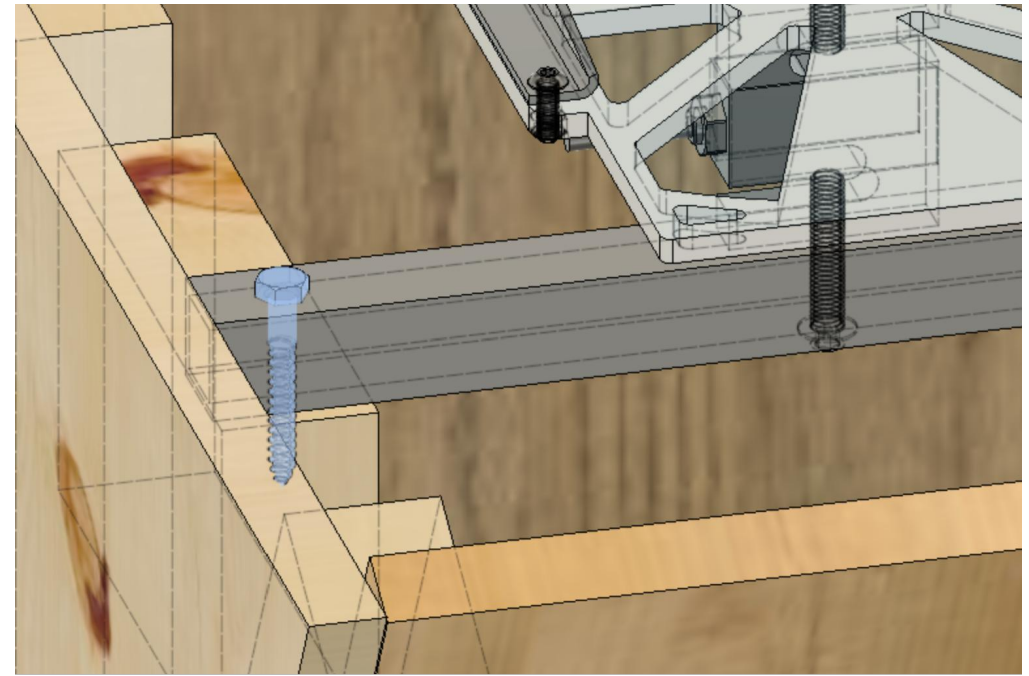
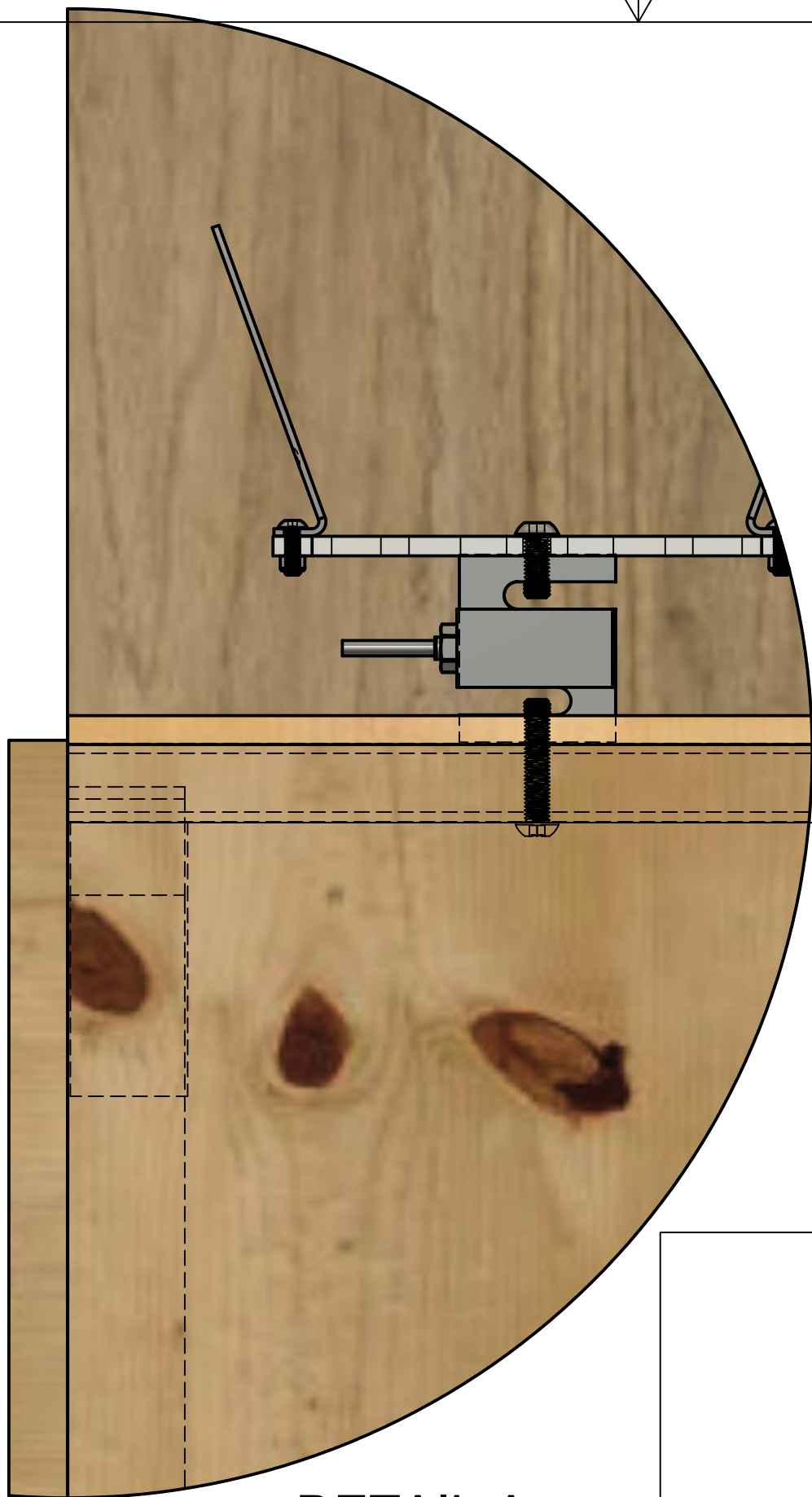
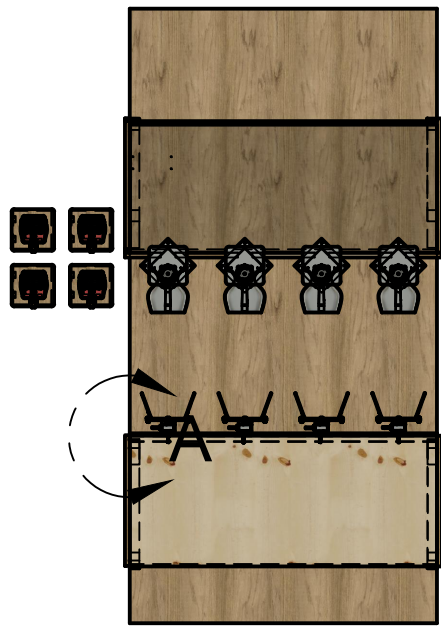

1" aluminum square tube is commonly available and a M8 - 40 bolt can be drilled through the aluminum and supported by 2 2x4s screwed into the side scale support pieces of plywood. The top of the 2x4 should be 1" from the top of the side panels so that the 1" square tube can be flush with the top of the side panels.

Secure the square tube with wood lag screws into the 2x4 tight to prevent too much scale vibration when filling.

Holes in the 48" long square tube can be drilled at 6" from the ends and 12" in between each for a total of 4 holes for 4 scales.

If you have a smaller quantity of baggers, you can drill the holes for future expansion while it is easy.

1in

DETAIL A
SCALE 1/2" = 1"

		PROJECT		
		Fenrir Bagger Hopper Plans		
		TITLE		
		Support Bar, support and holes		
APPROVED	SIZE	CODE	DWG NO	REV
CHECKED	B			
DRAWN Fenrir	2022-05-20	SCALE 1:30	WEIGHT	SHEET 2/3

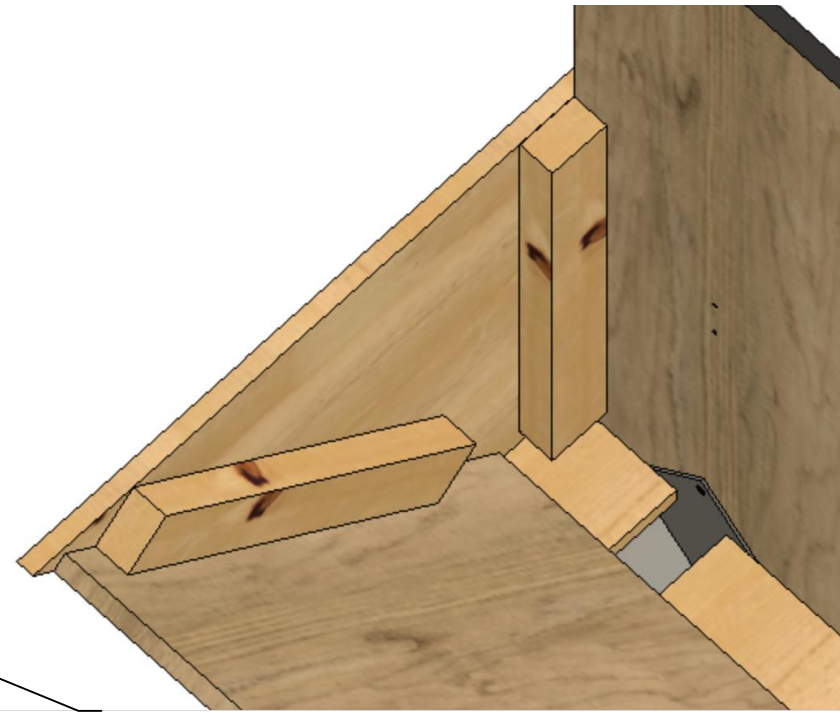
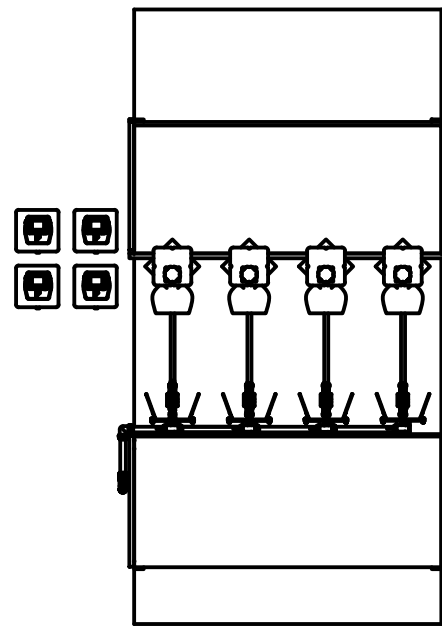

Mount Baggers using $\frac{7}{8}$ wood screws through holes on the steel trough. Space center of bagger holes at 6" from edge of the plywood and then 12" between them on center

Bottom of the hopper can be made with flat pieces to allow pellets to flow down into auger.

Gaps can be sealed with spray foam, tape or precisely cut wood.

Combo pellets can stay in the hopper between sessions so no need to empty the hoppers between runs.

		PROJECT		
		Fenrir Bagger Hopper Plans		
		TITLE		
		Support Bar, support and holes		
APPROVED	SIZE	CODE	DWG NO	REV
CHECKED	B			
DRAWN	Fenrir	2022-05-20	SCALE 1:30	WEIGHT
			SHEET 3/3	